Cherkez R.G., *doc. phys. - math. sciences, acting Professor*^{1,2}



Cherkez R.G.

¹Institute of Thermoelectricity of the NAS and MES of Ukraine,
1, Nauky str., Chernivtsi, 58029, Ukraine

²Yuriy Fedkovych Chernivtsi National University,
2, Kotsiubynsky str., Chernivtsi, 58012, Ukraine

INFLUENCE OF PLATE THICKNESS ON THE EFFICIENCY OF A PERMEABLE PLANAR COOLING THERMOELEMENT

This paper presents the theory of calculation and computer methods of search for optimal parameters (electric current density, heat carrier flow rate) of a permeable planar cooling thermoelement whereby the energy conversion efficiency will be maximum. The thickness of leg plates of a permeable thermoelement based on Bi-Te at which the coefficient of performance will be maximum is calculated. It is shown that the rational use of such energy converters allows increasing the coefficient of performance by 20-40 %. Bibl. 9, Fig. 2, table 1.

Key words: *thermoelectric materials, coefficient of performance, cooling capacity, design of a permeable planar thermoelement.*

Introduction

There are thermoelements in which heat exchange with the heat source and sink occurs not only on the thermoelement junctions, but also in the bulk of the leg material [1 – 3]. Variants of implementation of such models are permeable thermoelements where in the leg material along the direction of electric current flow there are channels (pores) for pumping of the heat carrier. By controlling the heat transfer conditions (heat carrier velocity, heat transfer intensity, etc.) in combination with the distribution of physical effects in the leg material, it is possible to influence the energy conversion efficiency.

The study of permeable thermoelements [3 – 5] showed a good outlook for their use, since it allows increasing the coefficient of performance by a factor of 1.3-1.6.

However, their practical implementation is related to certain material research and technological difficulties, which encourages the search and study of simpler variants of physical models of converters with internal heat transfer.

A variant of implementation of internal heat exchange are permeable planar thermoelements where each leg consists of a certain number of plates spaced apart. The gaps between the plates form channels through which the heat carrier (liquid or gas) is pumped.

Research on such thermoelements with a view to determine the optimal thickness of plates and maximum characteristics of energy conversion is a relevant task, which is the purpose of this paper.

Physical model and its mathematical description

A physical model of a planar permeable thermoelement working in the mode of thermoelectric cooling is shown in Fig. 1. It comprises n - and p -type legs, each leg consisting of N_p segments (planes) that are h_k apart. The width of the segment is h , and its thickness – h_p . The gaps between the segments

form channels through which the heat carrier (air or liquid) is pumped to cool it. The hot and cold junctions of the thermoelement are maintained at constant values of T_h and T_c , respectively. The coolant is pumped in the direction from the hot to cold junctions. The temperature of the heat carrier at the inlet of the thermoelement is T_a . The heat transfer coefficient of the heat carrier inside the channels of a permeable planar thermoelement is α_T .

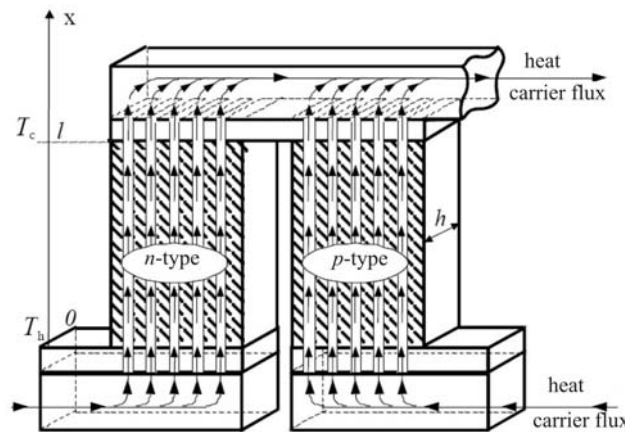

Fig. 1. Model of a permeable planar thermoelement.

To find the distribution of temperatures in thermoelement material, it is necessary to solve a differential equation

$$\frac{d}{dx} \left(\kappa(T) \frac{dT}{dx} \right) + i^2 \rho(T) - Ti \frac{d\alpha(T)}{dx} - \frac{2 \alpha_T}{h_p} (T - t) = 0, \quad (1)$$

Where t is heat carrier temperature at point x ; T is leg temperature at point x ; α_T is heat transfer coefficient; i is electric current density ($i = I/S - S_K$); $\alpha(T)$, $\kappa(T)$, $\rho(T)$ – the Seebeck coefficient, thermal conductivity and resistivity of material are functions of temperature T . Note that thermoelectric medium parameters α , κ , ρ are interdependent. The system of these relations sets certain area G_ξ of change in the inhomogeneity ξ . Specifying material of the leg, one must assign these relations, for instance, in the form of theoretical or experimental dependences of α , κ , ρ on T and determine G_ξ .

On the area of leg segment dx , a change in heat carrier temperature dt is determined by the law of conservation of energy. A differential equation for the distribution of heat carrier temperature t is of the form

$$\frac{dt}{dx} = \frac{2 \alpha_T}{V c_p h_p} (T - t). \quad (2)$$

where V is specific mass velocity of heat carrier in the channel ($V = v \rho_T$; v is velocity, ρ_T is heat carrier density); c_p is specific heat of heat carrier.

Eqs. (1) and (2), written for n - and p -type thermoelement legs, form a system of differential equations to determine the distribution of temperatures.

$$\left\{ \begin{array}{l} \frac{d}{dx} \left(\kappa(T, \xi) \frac{dT}{dx} \right) + i^2 \rho(T, \xi) - \\ - Ti \frac{d\alpha(T, \xi)}{dx} - \frac{2\alpha_T}{h_p} (T - t) = 0, \\ \frac{dt}{dx} = \frac{2\alpha_T}{Vc_p h_p} (T - t). \end{array} \right. \quad (3)$$

Consider the problem of the maximum energy efficiency of thermoelectric cooling at fixed temperatures of heat sources T_h and T_c .

The problem reduces to finding coefficient of performance maximum

$$\varepsilon = \frac{Q_c}{Q_h - Q_c}, \quad (4)$$

at differential relations (3) and boundary conditions:

$$T_{n,p}(0) = T_h, \quad T_{n,p}(1) = T_c, \quad t_{n,p}(0) = T_s. \quad (5)$$

where T_h is the hot side temperature of junctions, T_c is the cold side temperature of junctions, T_s is the initial temperature of heat carrier; Q_h , Q_c , are thermal fluxes which the thermoelement exchanges with the external heat sources

$$Q_h = Q_n(0) + Q_p(0),$$

$$Q_c = Q_n(1) + Q_p(1) + Q_L,$$

where Q_L is the heat supplied due to internal heat exchange

$$Q_L = \sum_{n,p} Vc_p S_R (t(0) - t(1)).$$

Hereinafter, instead of maximum ε it is convenient to consider minimum of functional I:

$$I = \ln q(0) - \ln q(1), \quad (6)$$

where

$$q(0) = \frac{Q_h}{I} = q_n(0) + q_p(0),$$

$$q(1) = \frac{Q_c}{I} = q_n(1) + q_p(1) + \frac{Q_L}{j(S - S_K)} I,$$

where $q_n(1), q_p(1), q_n(0), q_p(0)$ are the values of specific heat fluxes on the cold and hot thermoelement junctions for n and p -type legs that are determined from solving the system of differential equations (3).

The optimization problem is to choose from the control area $\xi \in G_\xi$ such concentration functions $\xi^{n,p}(x)$ and simultaneously assign such a specific mass velocity of heat carrier in the channels $V=V_0$ which under restrictions (3),(4) and the condition for electric current density

$$q_n(1) + q_p(1) = 0, \quad (7)$$

impart to functional I the lowest value, in which case the coefficient of performance ε will be maximum [7].

Problem solving method and calculation results

To solve the problem, we use the mathematical optimal control theory, developed under the guidance of L.S. Pontryagin, as applied to permeable thermoelements [8]. We specify the formalism of the mathematical optimal control theory in relation to our problem.

Functions $\psi(x)$ (pulses) must satisfy a system of equations that is canonically conjugate to system (3) and is given by:

$$\left. \begin{aligned} \frac{d\psi_1}{dx} &= \frac{\alpha j}{\kappa} R_1 \psi_1 - \left(\frac{\alpha j}{\kappa} R_2 - \frac{\alpha_T \Pi_K N_K l^2}{(S - S_K) j} \right) \psi_2 \\ &\quad - \frac{\alpha_T \Pi_K N_K l}{V c_p S_R} \psi_3, \\ \frac{d\psi_2}{dx} &= \frac{j}{\kappa} \psi_1 - \frac{\alpha j}{\kappa} \psi_2, \\ \frac{d\psi_3}{dx} &= - \frac{\alpha_T \Pi_K N_K l^2}{(S - S_K) j} \psi_2 + \frac{\alpha_T \Pi_K N_K l}{V c_p S_R} \psi_3. \end{aligned} \right\}_{n,p}$$

where

$$\left. \begin{aligned} R_1 &= 1 + \frac{d \ln \alpha}{dT} T - \frac{d \ln \kappa}{dT} \left(T + \frac{q}{\alpha} \right), \\ R_2 &= R_1 + \frac{1}{Z_K} \frac{d \ln \sigma}{dT} + \frac{d \ln \kappa}{dT} \left(T + \frac{q}{\alpha} \right). \end{aligned} \right\}_{n,p}$$

The boundary (transversality) conditions for this system are as follows:

$$\psi(0) = \frac{\partial \bar{J}}{\partial y} \Big|_{x=0}, \quad \psi(1) = - \frac{\partial \bar{J}}{\partial y} \Big|_{x=1}$$

where $\bar{J} = J + \sum (v, g)$ is an expanded functional; v, g are vectors of undetermined Lagrange multipliers and the boundary conditions (5).

Then the boundary conditions for the conjugate system will take on the form

$$\psi_2^{n,p}(0) = \frac{1}{q_n(0) + q_p(0)},$$

$$\psi_2^{n,p}(1) = -\frac{(S - S_K)j}{IVC_p S_R (2t(0) - t_n(1) - t_p(1))},$$

$$\psi_3^{n,p}(1) = -\frac{1}{2t(0) - t_n(1) - t_p(1)}.$$

Using the above system of equations with regard to relations (3),(5) and the numerical methods, we created a program of computer design of optimal functions of thermoelectric material inhomogeneity $\xi(x)$ and optimal heat carrier velocity V with a view to achieve maximum energy efficiency of a permeable planar cooling thermoelement.

Results of studying a permeable planar thermoelement for Bi-Te based materials

We present the results of computer design of the optimal inhomogeneity of semiconductor thermoelectric material in combination with the optimal distribution function of heat sources (sinks) for permeable planar cooling thermoelements. The heat transfer coefficient of the heat carrier inside the channels was $0.01 \text{ W / cm}^2\text{K}$.

As the initial data for such optimization, the experimental temperature dependences of characteristics of n - and p -type *Bi-Te* based semiconductor materials α , σ , κ for various impurity concentrations were used [9].

Dependences of maximum coefficient of performance (COP), thermoelement cooling capacity (Qcc), power consumption (W), voltage (U), heat carrier temperature at the outlet from thermoelement (T_{c_v}), optimal heat carrier flow rate (V_o) on plate thickness (h_p) for the height of legs $l= 1.0 \text{ cm}$ are presented in the table

Таблиця

Залежності характеристик термоелемента від ширини пластини

| $h_p, \text{ cm}$ | 0.5 | 0.1 | 0.05 | 0.01 | 0.005 |
|---|-------|--------|--------|--------|--------|
| COP | 0.524 | 0.566 | 0.574 | 0.581 | 0.58 |
| $Q_c, \text{ Вт}$ | 2.660 | 0.5654 | 0.2869 | 0.0582 | 0.029 |
| $W, \text{ W}$ | 5.06 | 0.999 | 0.500 | 0.100 | 0.050 |
| $U, \text{ V}$ | 0.071 | 0.071 | 0.071 | 0.071 | 0.071 |
| $T_{c_v}, \text{ K}$ | 280.3 | 255.1 | 252.5 | 250.5 | 250.25 |
| $V_{opt}, \text{ kg}/(\text{cm}^2 \text{ s})$ | 0.135 | 0.0126 | 0.006 | 0.0012 | 0.0006 |

It is seen that there is an optimal plate thickness (0.1 cm) whereby the characteristics of the thermoelement have the most favorable values.

The results of calculation of the influence of channel width on the characteristics of a permeable thermoelement with the number of channels 10 pcs, the height of legs 1 cm are presented in Fig. 2. The plots of characteristics of a permeable planar cooling thermoelement (coefficient of performance ϵ , heat flux Q , heat carrier velocity V) on channel width H_K are constructed here.

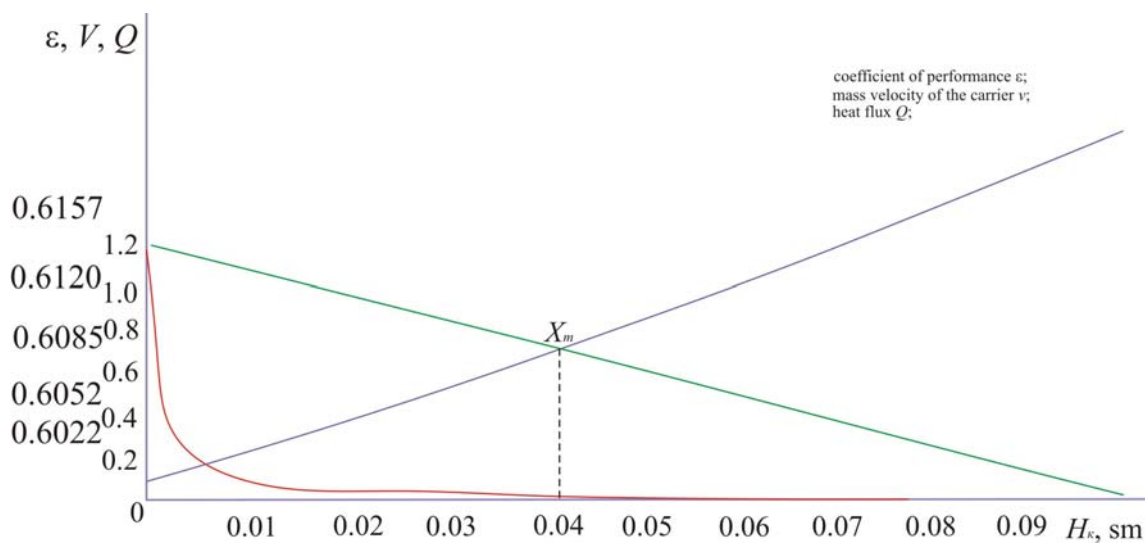

Fig. 2. Dependence of coefficient of performance ε , heat carrier velocity V and heat flux Q on channel width.

The intersection of the two lines will show us the rational value of channel width whereby the cooling capacity and coefficient of performance will have the most favorable values. In this case, channel width is approximately 0.04 cm

Efficiency comparison with classical thermoelements indicates the possibility of improving the coefficient of performance by a factor of 1.2-1.4.

Conclusions

1. The optimal thickness of leg plate whereby the thermoelement characteristics have the most favourable values for *Bi-Te* based material is 0.1 cm.
2. The use of permeable thermoelectric coolers of such power converters allows increasing the coefficient of performance by 20-40%.
3. The results demonstrate the prospects of research and creation of permeable planar thermoelectric coolers.

The author expresses gratitude to academician of the NAS of Ukraine L.I. Anatyshuk. for valuable remarks on the work, the chief researcher of the Institute of Thermoelectricity L.M. Vikhor for discussing the peculiarities of the application of optimal control theory method, students of ChNU V. Toronchuk and the college of ChNU A. Zhukova for assistance in plotting, visualization of computer research results.

References

1. Kozliuk V.N., Shchegolev G.M. (1973). Termodinamicheskii analiz pronitsaiemykh termoelektricheskikh kholodilnikov [Thermodynamic analysis of permeable thermoelectric coolers]. *Teplotfizika i teplotekhnika – Thermophysics and Heat Engineering*, issue 25, 96-100 [in Russian].
2. Kotyrlo G.K., Kozliuk V.N., Lobunets Yu.N. (1975). Termoelektricheskii generator s razvitoi poverkhnosti teploobmena [Thermoelectric generator with a developed heat exchange surface].

- Teplotekhnicheskiie problemy priamogo preobrazovaniia energii – Thermotechnical Problems of Direct Power Conversion*, issue 7, 85-95 [in Russian].
3. Lobunets Yu.N. (1989). *Metody rascheta i proektirovaniia termoelektricheskikh preobrazovatelei energii [Methods for calculation and design of thermoelectric power converters]*. Kyiv: Naukova Dumka [in Russian].
 4. Anatyshuk L.I., Cherkez R.G. (2003). On the properties of permeable thermoelements. *Proc. of XXII Intern. Conf. on Thermoelectrics* (France), 480-483.
 5. Cherkez R.G. (2003). Thermoelements with internal and lateral heat exchange. *J. Thermoelectricity*, 1, 70-77.
 6. Anatyshuk L.I., Vikhor L.N., Cherkez R.G. (2000). Optimal control of the inhomogeneity of semiconductor material for permeable cooling thermoelements. *J. Thermoelectricity*, 3, 46-57.
 7. Pontriagin L.S., Boltianskii V.G., Gamkrelidze R.V., Mishchenko E.F. (1976). *Matematicheskaiia teoriia optimalnykh processov [Mathematical theory of optimal processes]*. Moscow: Nauka [in Russian].
 8. Cherkez R.G. (2016). On the simulation of permeable thermoelements. *J. Thermoelectricity*, 1.
 9. Anatyshuk L.I., Vikhor L.N. (2012). *Thermoelectricity. Vol. 4. Functionally graded thermoelectric materials*. Chernivtsi: Bukrek.

Submitted 21.08.2019

Черкез Р.Г. док. фіз.-мат. наук, в.о. професора^{1,2}

¹Інститут термоелектрики НАН і МОН України, вул. Науки, 1,
Чернівці, 58029, Україна, e-mail: anatysh@gmail.com;

²Чернівецький національний університет ім. Юрія Федьковича,
вул. Коцюбинського 2, Чернівці, 58000, Україна

ВПЛИВ ТОВЩИНИ ПЛАСТИН НА ЕФЕКТИВНІСТЬ РОНІКНОГО ПЛОЩИННОГО ТЕРМОЕЛЕМЕНТА ОХОЛОДЖЕННЯ

Представлено теорію розрахунку та комп'ютерні методи пошуку оптимальних параметрів (густина електричного струму, витрати теплоносія) проникного площинного термоелемента охолодження, при яких ефективність перетворення енергії буде максимальною. Розрахована товщина пластин вітки проникного термоелемента на основі матеріалу Bi-Te, при якій холодильний коефіцієнт буде максимальним. Показано, що раціональне використання таких перетворювачів енергії дозволяє підвищити холодильний коефіцієнт на 20-40 %. Бібл. 9, рис. 2, таблиця 1.

Ключові слова: термоелектричні матеріали, холодильний коефіцієнт, холодопродуктивність, проектування проникного площинного термоелемента.

Черкез Р.Г. ^{1,2}, док. фіз.-мат. наук, в.о. професора^{1,2}

¹Інститут термоелектричества НАН и МОН Украины ул. Науки, 1,
Черновцы, 58029, Украина; e-mail: anatysh@gmail.com;

²Черновицкий национальный университет имени Юрия Федьковича,

ул. Коцюбинського 2 Черновцы, 58012, Украина

ВЛИЯНИЕ ТОЛЩИНЫ ПЛАСТИН НА ЭФФЕКТИВНОСТЬ ПРОНИЦАЕМОГО ПЛОСКОСТНОГО ТЕРМОЭЛЕМЕНТА ОХЛАЖДЕНИЯ

Представлены теория расчета и компьютерные методы определения оптимальных параметров (плотность электрического тока, расхода теплоносителя) проницаемого плоскостного термоэлемента охлаждения, при которых эффективность преобразования энергии максимальна. Рассчитана толщина пластин ветви проницаемого термоэлемента на основе материала Bi-Te, при которой холодильный коэффициент максимален. Показано, что рациональное использование таких преобразователей энергии позволяет повысить холодильный коэффициент на 20-40 %. Библ. 9, рис. 2 таблица 1.

Ключевые слова: термоэлектрические материалы, холодильный коэффициент, холодопроизводительность, проектирование проницаемого плоскостного термоэлемента

References

- 10.Kozliuk V.N., Shchegolev G.M. (1973). Termodinamicheskii analiz pronitsaiemykh termoelektricheskikh kholodilnikov [Thermodynamic analysis of permeable thermoelectric coolers]. *Teplofizika i teplotekhnika – Thermophysics and Heat Engineering*, issue 25, 96-100 [in Russian].
- 11.Kotyrla G.K., Kozliuk V.N., Lobunets Yu.N. (1975). Termoelektricheskii generator s razvitoi poverkhnosti teploobmena [Thermoelectric generator with a developed heat exchange surface]. *Teplotekhnicheskiye problemy priamogo preobrazovaniia energii – Thermotechnical Problems of Direct Power Conversion*, issue 7, 85-95 [in Russian].
- 12.Lobunets Yu.N. (1989). *Metody rascheta i proektirovaniia termoelektricheskikh preobrazovatelei energii [Methods for calculation and design of thermoelectric power converters]*. Kyiv: Naukova Dumka [in Russian].
- 13.Anatyshuk L.I., Cherkez R.G. (2003). On the properties of permeable thermoelements. *Proc. of XXII Intern. Conf. on Thermoelectrics* (France), 480-483.
- 14.Cherkez R.G. (2003). Thermoelements with internal and lateral heat exchange. *J.Thermoelectricity*, 1, 70-77.
- 15.Anatyshuk L.I., Vikhor L.N., Cherkez R.G. (2000). Optimal control of the inhomogeneity of semiconductor material for permeable cooling thermoelements. *J.Thermoelectricity*, 3, 46-57.
- 16.Pontriagin L.S., Boltianskii V.G., Gamkrelidze R.V., Mishchenko E.F. (1976). *Matematicheskaya teoriya optimalnykh processov [Mathematical theory of optimal processes]*. Moscow: Nauka [in Russian].
- 17.Cherkez R.G. (2016). On the simulation of permeable thermoelements. *J.Thermoelectricity*, 1.
- 18.Anatyshuk L.I., Vikhor L.N. (2012). *Thermoelectricity. Vol. 4. Functionally graded thermoelectric materials*. Chernivtsi: Bukrek.

Submitted 21.08.2019